

SureFlow Plus Series

Models: CPF2100, CPF4100-3,
CPF4100-6 CPF6100, CPF210,
CPF310, CPF510, CPF520-3, CPF520-6

Auto-Fill Catering Water Boiler
with Integrated Multi-Filter

Installation and User Instructions



The Professional's Choice



INSTANTA LIMITED
Canning Road, Southport, Merseyside,
PR9 7SN
Tel: (01704) 501114 Fax: (01704) 501115
IB30 - ISS: 02

CONTENTS

CONTENTS & INTRODUCTION	1
SAFETY, ENVIRONMENTAL INFORMATION & DELIVERY CHECK-LIST	2
TECHNICAL SPECIFICATION	3
INSTALLATION	3
OPERATION (including set-up of clock time)	4
ECO MODE / ENERGY SAVING	5
DAILY USE	5
MULTI-FILTER & FILTER REPLACEMENT	5
ADJUSTING FILTER-MONITOR (optional)	7
SEVEN-DAY TIMER	8
CLEANING	9
MAINTENANCE, SPARES & SERVICE INFORMATION	9
SERVICE WARNINGS & FAULT DIAGNOSTICS	9-10
SERVICE / TECHNICAL SUPPORT	11
GUARANTEE	11

Introduction

Dear Customer,

Thank you for purchasing this Instanta product.

Your new water boiler is designed to give you years of trouble-free service provided that the instructions contained in this manual are followed.

All new series Instanta products are energy efficient, simple to operate and easy to service. Find out more about Instanta products at www.instanta.com

Safety Information

Please read the following carefully before starting work on this equipment.

A competent person should install this appliance in accordance with the installation instructions for this appliance and all relevant local and national standards including the following:

- Health & Safety at Work Act
- IEE Regulations
- Local & National Building Regulations
- BS Codes of Practice
- Water Supply Regulations

All personnel should be provided with sufficient training in the safe use of this appliance.

- Inform users that certain surfaces will become hot (especially the draw-off tap). Care should be taken to avoid potential injury from burns and scalding whilst operating this appliance.
- In line with Health and Safety requirements we recommend a risk assessment be carried out after the boiler has been installed.
- Always disconnect the unit from the power supply before servicing.
- The unit must be earthed.
- Keep these instructions in a safe place near the unit for future reference

This appliance is not intended for use by persons (Including Children) with reduced physical, sensory or mental capabilities, or lack of experience and knowledge, unless they have been given supervision or instruction concerning use of the appliance by a person responsible for their safety. Children should be supervised to ensure they do not play with the appliance.

Environmental (Information On Disposal For Users Of Waste Electrical & Electronic Equipment)

The “crossed out wheelie bin” symbol on this product means that discarded electrical and electronic products should not be mixed with general waste. Disposing of the product correctly will help to save valuable resources and prevent any potential negative effects on human health and the environment which could otherwise arise from inappropriate waste handling. For proper treatment, recovery and recycling of end-of-life products, please contact your dealer or supplier for further information, or local authority for details of your nearest designated collection point.

Delivery Checklist

Before starting installation, check that you have the following parts;

- Catering Water Boiler
- Drip-tray
- Rubber tapered over-flow bung (use when directing over-flow to permanent waste at rear)
- White water inlet hose (3/4”BSP connection)
- User instructions

Technical Specification

Model	Width	Depth	Height	Tap Clearance	Power Rating	Weight (empty)	Weight (full)	Water Inlet Pressure
	mm	Mm	Mm	mm	kW	KG	KG	Bar
CPF2100	260	555	610	200	3.0	15.3	29.1	2 to 7
CPF4100-3	360	555	610	200	3.0	17.5	39.0	2 to 7
CPF4100-6	360	555	610	200	6.0	17.8	39.3	2 to 7
CPF6100	440	555	610	200	6.0	21.4	53.0	2 to 7
High-tap units:								
CPF210	260	555	705	304	3.0	16.3	30.1	2 to 7
CPF310	260	555	705	304	6.0	16.8	30.6	2 to 7
CPF510	360	555	705	304	3.0	18.0	39.5	2 to 7
CPF520-3	360	555	705	304	3.0	18.5	40.0	2 to 7
CPF520-6	360	555	705	304	6.0	18.8	40.3	2 to 7

Installation

The boiler must be installed on a horizontal work surface with sufficient strength to support its weight.

Locate in an area where there is adequate space to use the boiler safely (e.g. free from risk of congestion and tripping hazards).

Connection to Mains Water Supply:

Connect the WRAS approved water filling hose (3/4" BSP) to the inlet connection point on the back of the boiler and the other end to the mains water supply, via an accessible isolating tap with a 3/4" BSP thread.

IMPORTANT: If micro-bore pipe is used instead of the inlet hose supplied, the size must be minimum OD 3/8"(10mm).

The water supply must have a pressure not exceeding 7bar (96psi), and no lower than 2bar (28psi) NOTE: If your water pressure exceeds 7bar, fit a suitable pressure reduction valve.

We regret that Instanta cannot be held responsible for any machine malfunctions if the water pressure exceeds that stated. If in doubt, consult your water supply company

Electrical Connection:

The boiler must be Earthed.

All 3.0KW models:Your machine is supplied with a standard 13amp bonded plug with a 13amp fuse.

All 6.0KW models:

Your machine is supplied with a 1.5mtr cord (3-core @ 2.5mm). Wire to at least a 30amp supply via an all-pole disconnection isolator switch (easily accessible for safety). Only a qualified electrician should undertake this work.

Overflow:

The drip-tray has a limited capacity and is designed to handle small spillages and drips. Wherever possible, we strongly recommend that it is connected to a permanent waste.

We have provided two overflow outlet/connection points to choose from;

1). FRONT via drip-tray

If this option is used for the overflow, we can supply a 15mm fitting kit (Pt. No: DTK2) available from Instanta Spares Department (01704 502905).

2). REAR via outlet at back of machine

If rear overflow option is preferred, the front overflow-outlet (see diagram below), must be blocked off using the tapered-rubber blanking bung provided. Pipework should then be provided between the back of the machine [1/2" bsp – 15mm], and a suitable waste/drain.

NOTE: An air gap must be provided within 300mm of the connection point. Failure to provide an air gap within this distance could cause an air lock which could stop the water discharging in the event of an overflow.

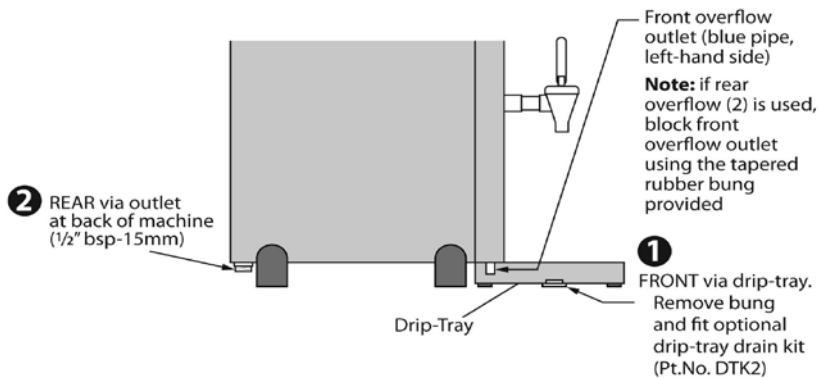

IMPORTANT: Whichever overflow connection is chosen, the diameter of the pipe used must be no less than 15mm.

Failure to connect the overflow-outlet to a permanent waste or drain, could lead to property damage from flooding.

If in all circumstances, it is absolutely not possible to direct the boiler overflow-outlet to a permanent waste or drain, then the mains water supply to the boiler should be isolated and the unit switched off whenever it is left unattended for long periods (e.g. overnight).

Whilst every reasonable precaution is taken to prevent an overflow, Instanta cannot be held responsible for any damage caused as a result of incorrect installation or blockage of the overflow or failure to direct the overflow to a safe outlet.

Operation

First use (once water and electrical connections have been made);

- Switch boiler on. The screen will light up red and will run through an initial self-diagnostic check before starting to fill with water (screen reads; “NOT READY FILLING”).
- Once primed with water, the boiler will begin to heat (screen reads; “NOT READY HEATING”).
- When the correct temperature has been reached, the display will change from Red to White and will simply read “READY”.
- The boiler will then continue in a heat/fill cycle until the tank is at full capacity. (During the heat/fill cycle, small amounts of water are added to ensure the water at the tap is always at the correct temperature).

IMPORTANT NOTE: In normal daily use, the boiler may be used as soon as the “READY” message is displayed, but on first install, wait at least 15 minutes before starting to use.

- Drain off approximately 10 litres of water (to flush the new filter cartridge through).
- The boiler is now ready for use.

Set Clock Time (24h) & Day:

- Enter USER set-up menu by first switching boiler off.
- Press & hold ON/OFF button for approximately 7 seconds (display will illuminate Yellow and screen will read “USER PROG”, before showing “HOUR”).
- Press & hold ON/OFF button (long push) so screen displays hour.
- To change the hour setting, press ON/OFF button (short pushes) until correct hour is displayed.
- To save, press ECO button (short push & release).
- Press ON/OFF button again to advance screen to “MIN”. Again press & hold button (long push) so screen displays minutes.
- Set “minutes” using short pushes of button as above and save by pressing ECO button.

- Similarly, set the DAY of the week (e.g. Sun=1, Mon=2, Tue=3 etc).
- To exit user menu, press & hold ECO button for approximately 5 seconds then release. (Screen will show “WAIT” whilst any changes are being saved).

To Enable and Set-up Seven-day Timer – see page 8

Eco Mode/Power Saving

The ECO mode is activated by pressing the ECO button (leaf symbol). The screen changes to Green. This saves energy by switching the boiler operating capacity to half volume, ideal on quiet days in the season. Simply push the ECO button again to revert to full capacity.

Regular Daily Use

Switch boiler on and wait for the screen to turn white and show “READY” message. The water will then be at the correct temperature.

Dispense water via the lever tap.
(CAUTION: Boiler dispenses near-boiling water).

AQ35 Multi-Filter

Instanta’s new built-in filtration system ensures that water is always to the highest standard, whilst delivering lower maintenance costs and improved energy efficiency.

Quick and easy to change, the new filter reduces sediment, chlorine taste & odour, and lime-scale via a slow release scale inhibitor, providing better water and therefore, better quality drinks.

Filter Replacement:

A series of bars on the FILTER display shows the estimated remaining life in the current filter cartridge. When the filter has just 200 Litres remaining (or a period of 6 months has expired), the filter icon will begin to flash as a reminder. When the filter needs replacing, the screen will show the message; CHANGE FILTER.

The boiler will continue to operate with the CHANGE FILTER screen but scale may build up more rapidly and the water taste may be affected.

Replace the filter as follows;

1. Switch boiler off and draw down water to tap level.



2. Open filter door

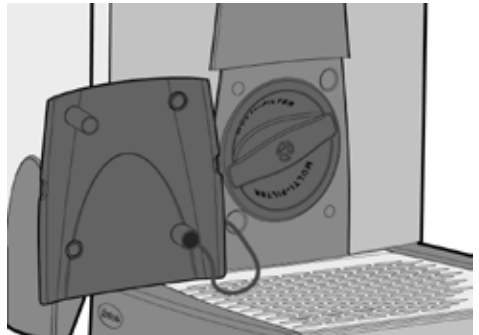

3. Grip Cartridge and rotate a quarter-turn to the left and pull forward. CAUTION: A small amount of water will drain from the head.



4. Align a flat screw-driver or similar with the tab on the filter and gently push.

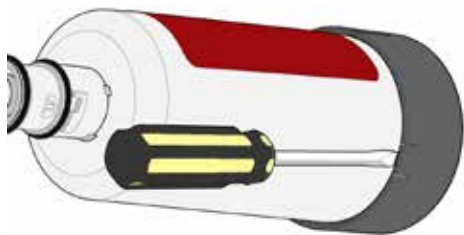

7. Remove protective cap from the top of the new cartridge and ensure the two rubber seals are in place.

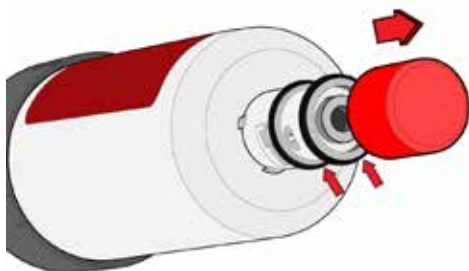

5. With one tab loosened, pull the filter cap off the old cartridge.



8. Insert new cartridge and turn until it locates. Install with a quarter-turn to the right until cartridge comes to a complete stop (Inlet water will automatically turn on). Close filter-door.



6. Align the shape on the inside of the filter cap (highlighted below) with the shape on the end of the new filter and push the two together until it clicks firmly in place.

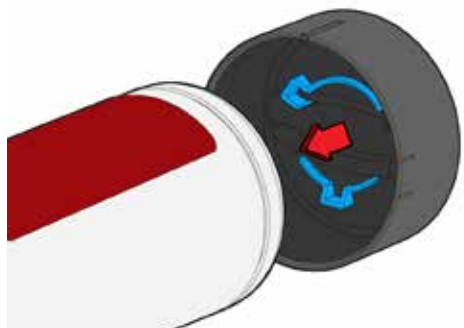

9. Switch back on and allow boiler to heat/fill for at least 15 minutes.



10. Drain-off approximately 10 litres of water (to flush new filter cartridge through).



11. TO RESET FILTER-LIFE MONITOR: ...Press and hold “On/Off” button for 10 seconds, screen will go blank before changing to red and displaying message “FILT 0000 LITRES” to confirm it has been reset.



The boiler is now ready for use.

Adjusting Filter Monitor (Optional):

The filter-life monitor is factory-set to 9001 litres (default) which is suitable for most parts of the UK with average or medium water hardness.

Hard and Soft Water: The effectiveness of the filter will be reduced in hard water areas (and should be replaced more frequently), or extended in soft water areas where scale is less of a problem.

If in doubt as to the hardness of water supplied in your area, consult your local water authority or Instanta Technical Support.

The filter-life monitor can be changed from the default setting, to suit the local water conditions in your area. As an example; locations with soft water might set the monitor between 11,000 to 14,000 litres, whereas locations with particularly hard water may choose to set between 5,000 to 7,000 litres.

To adjust filter-life monitor (optional);

Replace the filter cartridge (as steps 1 to 10 “AQ35 Filter Replacement” above). Then;

- With machine turned off, press & hold ON/OFF button (for approximately 7 seconds) until Yellow screen shows “USER PROG”, then release button.
- Advance through the menu options by pressing the ON/OFF button (short pushes), until “FSIZ” option is displayed.
- Press & hold button (long push) so screen displays filter size in litres.
- To change the litres setting, press ON/OFF button (short pushes) until desired filter size in litres is displayed (advances in 500 litre increments).
- To save new litres setting, press ECO button (short push & release).
- To exit USER menu, press & hold ECO button (long push – 5 seconds) then release. Screen will show “WAIT” whilst any changes are being saved, then go blank.
- Turn machine back on again.
- TO RE-SET & CONFIRM NEW SETTINGS; ...Press and hold ON/OFF button for 10 seconds, screen will go blank before changing to Red and displaying message “FILT 0000 LITRES” to confirm it has been reset (See step 11 above).

Filter Age

The age of the filter (in months), can be checked at any time. With boiler turned off, press & hold both the ON/OFF and ECO buttons together until screen shows “FAGE” and the number of months elapsed (e.g. 3 = 3 months old).

Filter-Life Monitor

The filter-life monitor can also provide an accurate reading of how many litres remain before the filter-cartridge expires. With boiler turned off, press & hold ON/OFF button until screen shows “0000 LITRES”.

7-Day Timer

The boiler can be set-up to switch ON and OFF using the programmable seven-day timer.

Enable 7-Day Timer:

- With machine switched off, press & hold ON/OFF button (for approximately 7 seconds) until Yellow screen shows “USER PROG”, then release button.
- Advance through options until “TMDE” is displayed (press & hold ON/OFF button to select).
- There are three options to choose:
 - ALL** – set ON and OFF times once and they apply to the full 7 day week.
 - ON** – set the ON and OFF times separately for each day of the week.
 - OFF** (Default) – the timer is disabled.
- Press ECO button to save the required option.

Set-up 7-Day Timer:

- Advance to next menu option “TMRS”. Again press & hold ON/OFF button (long push) to select.
- Set the ON and OFF times; use ECO button to advance the clock in 15 minute steps.
- Use the ON/OFF button to save the ON and OFF set-times, and also to cycle through the days of the week (All, Sun, Mon, Tue etc.)
- To exit USER menu, press & hold ECO button for 5 seconds then release (screen will show “WAIT” whilst the changes are being saved).

Overriding the Timer:

The timer can be overridden when in the “timed-off” period, simply by pressing the ON/OFF button on the front of the boiler. If the timer is overridden, the boiler will remain ON until the next programmed “time-off” period occurs, or until the boiler is switched off manually.

Cleaning

Clean the external surfaces of the boiler regularly to maintain good hygiene.

Empty the front drip-tray regularly.

Wipe external surfaces of the boiler with a damp cloth. Do not use abrasive materials on the outer surfaces.

Wipe the draw-off tap each day to keep clean and also prevent lime-scale deposits from building up around the tap-outlet.

Maintenance & Service Information

Filter:

Twist to the left and remove. See “AQ35 Filter Replacement” section above.

Descaling:

The boiler should be periodically checked for scale build-up...see below:

In hard water areas, the boiler should be descaled on a regular basis to maintain efficient operation, minimise energy consumption, and also retain the water quality. The frequency depends on the hardness of the local mains water supply and the regular replacement of the AQ35 filter cartridge.

To de-scale:

- Disconnect machine from power supply
- Empty the machine through the draw-off tap and allow to cool
- Remove outer-lid (spring-clips)
- Remove tank-lid (four/six fixing screws)
- Lift out the evaporation plates (inside of tank – Remember order of removal)
- Remove as much scale as possible by hand. Any scale which is difficult to remove can be dissolved by using a de-scaling solution
- Wipe clean the level sensing probes
- Flush with copious amounts of cold water to ensure all traces of de-scaler are removed before using the boiler again
- Replace evaporation plates, tank-lid and outer lid

Draw-off tap:

The draw-off tap components are subject to wear & tear. We strongly recommend that the tap is inspected periodically (at least once a year as part of a general maintenance routine). It is advisable to keep a spare tap assembly in case of emergencies.

Accessories & Spares (Tel: 01704 502905)

Tap Washer	TP1001/L
Tap Spring	TP1007/N
Tap Bonnet	HSTP100
Upper Tap Assembly	XTP1050/A

A full range of spares and accessories are available from our spares department.

Service Warnings and Fault Diagnosis

The majority of possible faults are covered overpage. However, in certain circumstances, safety controls within the boiler may be activated.

There are two resettable safety cut-outs in your boiler:

- 1). Over-boil safety cut-out – this will activate should the boiler produce excess steam.

This can be due to;

- lime-scale within the tank
- a temporary interruption in the water supply
- a faulty temperature sensor

To reset boiler; Switch off at the mains power supply and allow the boiler to cool down for ten minutes before switching back on (the safety device should automatically reset).

EARLIER MODELS: The over-boil cut-out will require a manual reset. Contact Instanta Technical Support department for assistance with this.

- 2). Boil-dry Safety cut-out. This operates if the boiler has been boiled dry, for example, due to lime scale build-up or water starvation.

The boil-dry safety switch will require resetting. Please contact our Technical Support department for assistance with this.

To reset boiler safety controls;



Safety Caution: Isolate boiler from power supply before removing any outer panels or attempting any reset.

CPF – XEF500 Fault Codes

	SCREEN MESSAGE	POSSIBLE CAUSES	ACTION
WHITE SCREEN	<p>READY</p>	<ul style="list-style-type: none"> Filter cartridge is exhausted and should be replaced as soon as convenient 	<ul style="list-style-type: none"> Replacement filter cartridge (available from Instanta Spares) <p>Part no: AQ35</p>
WHITE SCREEN	<p>CHECK WATER</p> <p>READY</p>	<ul style="list-style-type: none"> Water turned off Inlet hose kinked or bent Low incoming water pressure 	<ul style="list-style-type: none"> Check water supply and stop-cock Check incoming water supply is at minimum of 2 bar
YELLOW SCREEN	<p>CLEAN PROBES</p> <p>NOT READY</p>	<ul style="list-style-type: none"> Bottom probe not recognised 	<ul style="list-style-type: none"> Clean & de-scale probes Check probe wires are secure
YELLOW SCREEN	<p>⚠ CLEAN PROBES ⚠</p> <p>NOT READY</p>	<ul style="list-style-type: none"> Top probe not recognised. Water level has reached the de-scale probe 	<ul style="list-style-type: none"> Clean & de-scale probes
RED SCREEN	<p>⚠</p> <p>NOT READY</p> <p>OVER-FILL</p> <p>⚠</p>	<ul style="list-style-type: none"> Top probe & de-scale probe not recognised. Water level has reached the overfill probe 	<ul style="list-style-type: none"> Clean & de-scale probes Check water pressure is between 2 & 7 bar
RED SCREEN	<p>⚠</p> <p>NOT READY</p> <p>ELEM FAIL</p> <p>⚠</p>	<ul style="list-style-type: none"> Machine has over-heated (thermal safety-switch has activated or faulty) Thermistor disconnected or wires cut (in Ready mode) Element failed Boil-dry safety switch has tripped, or faulty 	<ul style="list-style-type: none"> Isolate machine and wait 10 minutes, then turn back on again Reset Switch Cut-Out (See above) De-scale tank. Reduce Temperature setting Call service if fault persists
RED SCREEN	<p>⚠</p> <p>NOT READY</p> <p>THERM DISC</p> <p>⚠</p>	<ul style="list-style-type: none"> Thermistor fault – disconnected or wires cut (on initial heat-up) 	<ul style="list-style-type: none"> Check thermistor is plugged securely into PCB and wires are not broken

Service/Technical Support:

Tel: 01704 502911

To ensure your service enquiry is handled as efficiently as possible, please have the following information available;

- Brief description of problem
- Product Type (model)
- Serial Number (label on right-hand side of machine). This is essential

Guarantee

Your boiler is guaranteed for three years from date of installation.

Our guarantee includes 2 years on site labour and three years parts for problems caused by fault of manufacture and component failure with the following exclusions:

- Problems caused by hard water and lime scale. We regret that we cannot be held responsible for problems caused by hard water
- Dripping Taps. These components are subject to wear and tear but in the event of a tap failing within two years of installation, we will be pleased to replace the tap assembly by post. Fitting is very simple and requires no tools. An engineer call out is not necessary.
- Accidental damage, misuse or use not in accordance with these instructions and damage caused by incorrect installation.
- The manufacturer disclaims any liability for incidental, or consequential damages.

