



# Instanta G2 InstaTap

Office Boiling 5 litre Matt Black

**FILTERED: BOILING**



**1 font included:**



**Also available in:**



POLISHED STAINLESS

Product code: I2B5

Actual product may vary slightly depending on functionality. The image shown is a representation only.

## Features and benefits

### Enhanced hygiene

Antimicrobial steritouch keypad that reduces 99.9% of surface bacteria, perfect for maintaining hygiene.

### Smooth water flow

Dispenses a smooth water flow to minimise spluttering and steam.

### User-safety options

The InstaTap is designed with a boiling safety lock which helps to prevent accidental dispense of boiling water and therefore lowers the risk of injuries as a result.

### Advanced filtration

The office InstaTap features a limescale and taste and odour filter to prevent the build up of limescale and to ensure your water always tastes and smells at its best.

### Choice of dispense

There are two options available: free pour and measured dispense.

| Model | Capacity | Heat up time (minutes) | Rapid draw off (litres) | Rapid draw off (cups)* | Boiling cups per hour* | Nominal power rating kW @ 230V | Command centre dimensions W x D x H |
|-------|----------|------------------------|-------------------------|------------------------|------------------------|--------------------------------|-------------------------------------|
| I2B5B | 5 Litres | 20                     | 5                       | 32                     | 135                    | 3                              | 230mm x 415mm x 420mm               |

\*Cups measured at 167ml

## Product detail

---

### Specification type

---

|              |  |
|--------------|--|
| Product code | I2B5B  |
| Product name | InstaTap G2 boiling 5ltr matt black for office |

---

### Capacity, weights & dimensions

---

|                               |  |
|-------------------------------|--|
| Water functions               | Boiling  |
| Boiling capacity              | 135 Cups per hour (default temperature setting at 96 °C) |
| Unit dimension (W x D x H)    | 230mm x 415mm x 420mm                                    |
| Product weight - empty / full | 9.9kg / 17.3kg   |

---

### Plumbing

---

|                                       |   |
|---------------------------------------|---|
| Wholesome water inlet supply required | Cold Feed   |
| Supply pressure range                 | 2 - 5 bar   |
| Supply connection                     | 1 x isolated 3/4" BSP BSP fitting (Install rail 15mm) |
| Installation                          | Must comply with current water supply regulations     |

---

### Electrical

---

|                             |   |
|-----------------------------|---|
| Command centre power rating | 2.25 kW @ 220-240V                        |
| Voltage supply              | 13 amps                                   |
| Power supply requirements   | 1 x 13amp socket outlet                   |
| Cable length                | 1.7m fitted with UK standard 3-pin plug   |
| Installation                | Must comply with current IEEE regulations |

---

## Font

|                               |                       |
|-------------------------------|-----------------------|
| Style                         | Standard              |
| Finish                        | Matt Black            |
| Dimensions (W x D x H)        | 150mm x 197mm x 275mm |
| Tap font clearance            | 195mm                 |
| Disability options            | No                    |
| Packed Dimensions (W x D x H) | 400mm x 215mm x 275mm |
| Packed weight                 | 4.6kg                 |

## Command Centre

|                                       |  |
|---------------------------------------|--|
| Factory temperature boiling           | 96°C   |
| Heat up time                          | 20 mins  |
| Stand by power loss (Idle over 24hrs) | 0.77 kW/h  |
| Wholesome water supply requirements   | Cold Feed  |
| Tank material                         | Stainless steel                                  |
| Filtration                            | Limescale Prevention Filter Cartridge 3,750 ltrs |
| Packed Dimensions (W x D x H)         | 340mm x 525mm x 510mm                            |
| Packed weight                         | 10.9kg   |

## Font installation

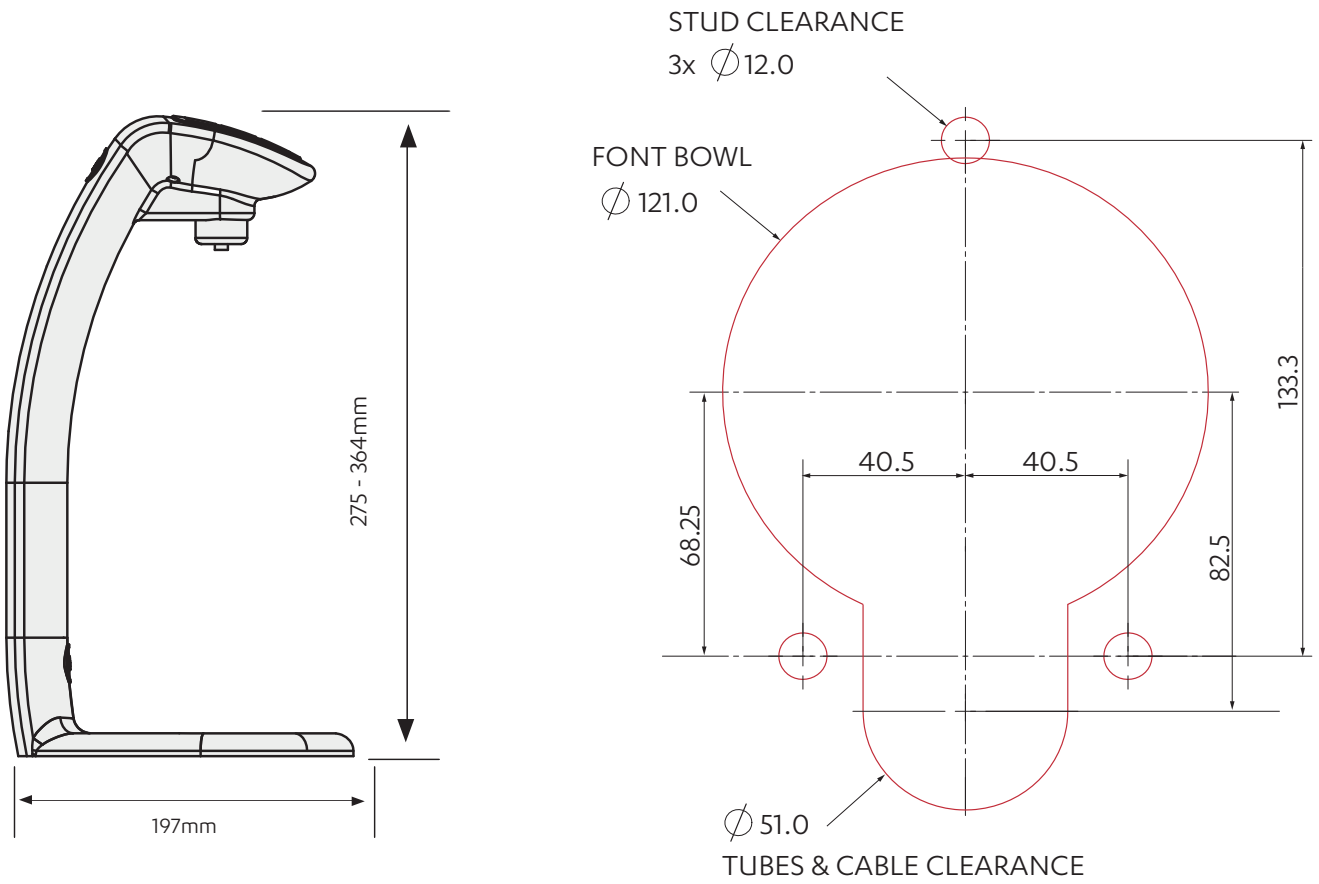

InstaTap mounting clearance - All dimensions in mm

## Under-counter unit installation

Clearance space required  
for under counter unit

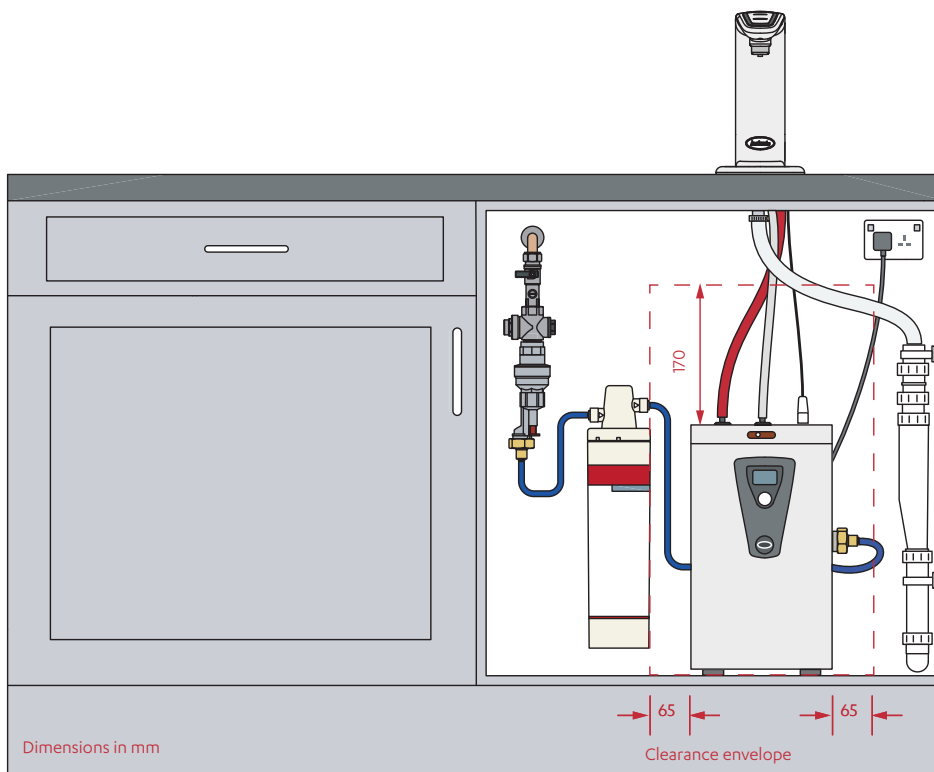

B office