



Instanta G2 InstaTap

Commercial Boiling 20 litre Polished Stainless Steel High

BOILING



1 font included:

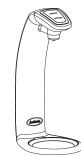

Also available in:



MATT BLACK

Product code: I2CB20BH

Actual product may vary slightly depending on functionality. The image shown is a representation only.

Features and benefits

Enhanced hygiene

Antimicrobial steritouch keypad that reduces 99.9% of surface bacteria, perfect for maintaining hygiene.

Smooth water flow

Dispenses a smooth water flow to minimise spluttering and steam.

Choice of dispense

There are three options available: free pour and 2 measured dispense.

Choice of design

Available in 2 heights and 2 finishes.

| Model | Capacity | Heat up time (minutes) | Rapid draw off (litres) | Rapid draw off (cups)* | Boiling cups per hour* | Nominal power rating kW @ 230V | Command centre dimensions W x D x H |
|---------|-----------|------------------------|-------------------------|------------------------|------------------------|--------------------------------|-------------------------------------|
| I2CB20H | 20 Litres | 43 | 20 | 120 | 180 | 3 | 390mm x 475mm x 568mm |

*Cups measured at 167ml

Product detail

Specification type

| | |
|--------------|--|
| Product code | I2CB20H |
| Product name | InstaTap G2 Commercial Boiling 20ltr polished stainless steel high |

Capacity, weights & dimensions

| | |
|-------------------------------|--|
| Water functions | Boiling |
| Boiling capacity | 180 Cups per hour (default temperature setting at 96 °C) |
| Unit dimension (W x D x H) | 390mm x 475mm x 568mm |
| Product weight - empty / full | 16.2kg / 38.5kg |

Plumbing

| | |
|---------------------------------------|---|
| Wholesome water inlet supply required | Cold Feed |
| Supply pressure range | 2 - 5 bar |
| Supply connection | 1 x isolated 3/4" BSP BSP fitting (Install rail 15mm) |
| Installation | Must comply with current water supply regulations |

Electrical

| | |
|-----------------------------|---|
| Command centre power rating | 3kW @ 220-240V |
| Voltage supply | 13 amps |
| Power supply requirements | 1 x 13amp socket outlet |
| Cable length | 1.7m fitted with UK standard 3-pin plug |
| Installation | Must comply with current IEEE regulations |

Font

| | |
|-------------------------------|--------------------------|
| Style | High |
| Finish | Polished stainless steel |
| Dimensions (W x D x H) | 150mm x 197mm x 364mm |
| Tap font clearance | 280mm |
| Disability options | No |
| Packed Dimensions (W x D x H) | 490mm x 215mm x 275mm |
| Packed weight | 5.15kg |

Command Centre

| | |
|---------------------------------------|-----------------------|
| Factory temperature boiling | 96°C |
| Heat up time | 43 mins |
| Stand by power loss (Idle over 24hrs) | 1.4 kW/h |
| Wholesome water supply requirements | Cold Feed |
| Tank material | Stainless steel |
| Packed Dimensions (W x D x H) | 462mm x 582mm x 660mm |
| Packed weight | 16.9kg |

Font installation

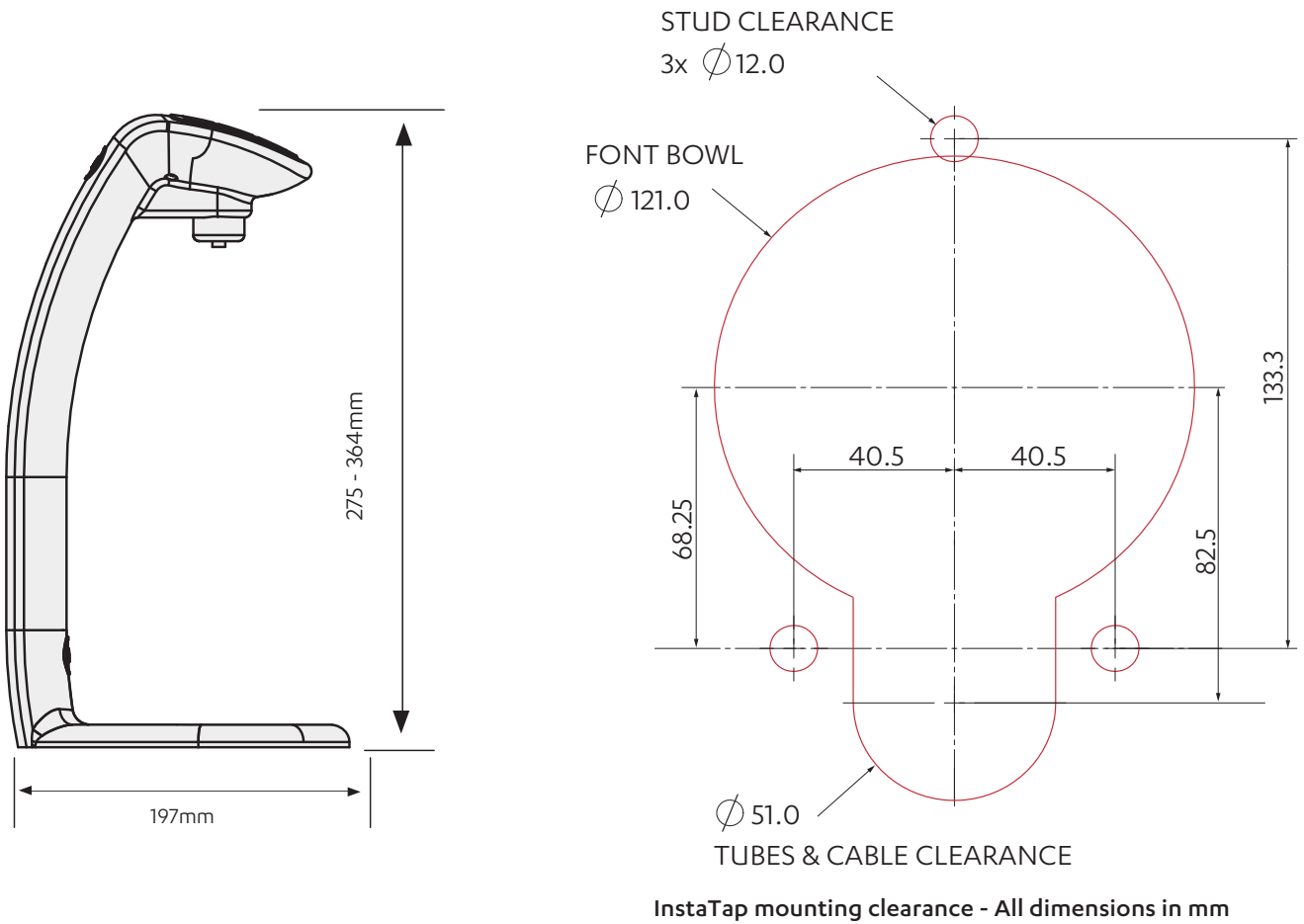

Under-counter unit installation

Clearance space required
for under counter unit

