



Instanta G2 InstaTap

Commercial Boiling 10 litre Chilled 20 litre Matt Black High

BOILING CHILLED



1 font included:



Also available in:



POLISHED STAINLESS

Product code: I2CBC1020H

Actual product may vary slightly depending on functionality. The image shown is a representation only.

Features and benefits

Enhanced hygiene

Antimicrobial steritouch keypad that reduces 99.9% of surface bacteria, perfect for maintaining hygiene.

Smooth water flow

Dispenses a smooth water flow to minimise spluttering and steam.

User-safety options

The InstaTap is designed with a boiling safety lock which helps to prevent accidental dispense of boiling water and therefore lowers the risk of injuries as a result.

Advanced filtration

The office InstaTap features a limescale and taste and odour filter to prevent the build up of limescale and to ensure your water always tastes and smells at its best.

Model	Capacity	Heat up time (minutes)	Boiling Rapid draw off (litres)	Boiling Rapid draw off (cups)*	Boiling cups per hour*	Chilled glasses per hour**	Nominal power rating kW @ 230V	Command centre dimensions W x D x H (mm)
I2CBC1020BH	Boiling - 10 Litres Chilled - 20 Litres	20	10	60	180	180	Boiling - 3 Chilled - 0.185	Boiling - 230 x 415 x 520 Chilled - 180 x 340 x 390

*Cups measured at 167ml
**Glasses measured at 200ml

Product detail

Specification type

Product code	I2CBC1020BH
Product name	InstaTap G2 Commercial Boiling 10ltr Chilled 20ltr matt black high

Capacity, weights & dimensions

Water functions	Boiling, Chilled
Boiling capacity	180 Cups per hour (default temperature setting at 96 °C)
Chilled capacity	180 Glasses per hour (temperature setting 3 -6 °C)
Boiling command centre dimension (W x D x H)	230mm x 415mm x 520mm
Chilled Command centre dimension (W x D x H)	180mm x 340mm x 390mm
Boiling command centre weight - empty / full	10.5kg / 22.5kg
Chilled command centre weight	17kg

Plumbing

Wholesome water inlet supply required	Cold Feed
Supply pressure range	2 - 5 bar
Supply connection	1 x isolated 3/4" BSP BSP fitting (Install rail 15mm)
Installation	Must comply with current water supply regulations

Electrical

Boiling command centre power rating	3kW @ 220-240V
Boiling voltage supply	13 amps
Boiling cable length	1.7m
Chilled command centre power rating	0.185kW @ 230V
Chilled command centre voltage supply	230V AC 50Hz
Chilled cable length	
Power supply requirements	2 x 13amp socket outlet with UK standard 3-pin plugs
Installation	Must comply with current IEEE regulations

Font

Style	High
Finish	Matt Black
Dimensions (W x D x H)	150mm x 197mm x 364mm
Tap font clearance	280mm
Disability options	No
Packed Dimensions (W x D x H)	4+0mm x 215mm x 275mm
Packed weight	1.7 kg

Boiling Command Centre

Factory temperature boiling	96°C
Heat up time	20 mins
Stand by power loss (Idle over 24hrs)	0.85 kW/h
Wholesome water supply requirements	Cold Feed
Tank material	Stainless steel
Packed Dimensions (W x D x H)	340mm x 525mm x 605mm
Packed weight	11.7 kg

Chilled Command Centre

Chilled performance	Between 3 °C and 6 °C
Stand by power loss (Idle over 24hrs)	0.12 kW/h
Wholesome water supply requirements	Cold Feed
Filtration	Limescale Taste and Odour Filter Cartridge 3,750 ltrs
Tank material	Stainless steel
Packed Dimensions (W x D x H)	460mm x 295mm x 640mm
Packed weight	20.5kg

Font installation

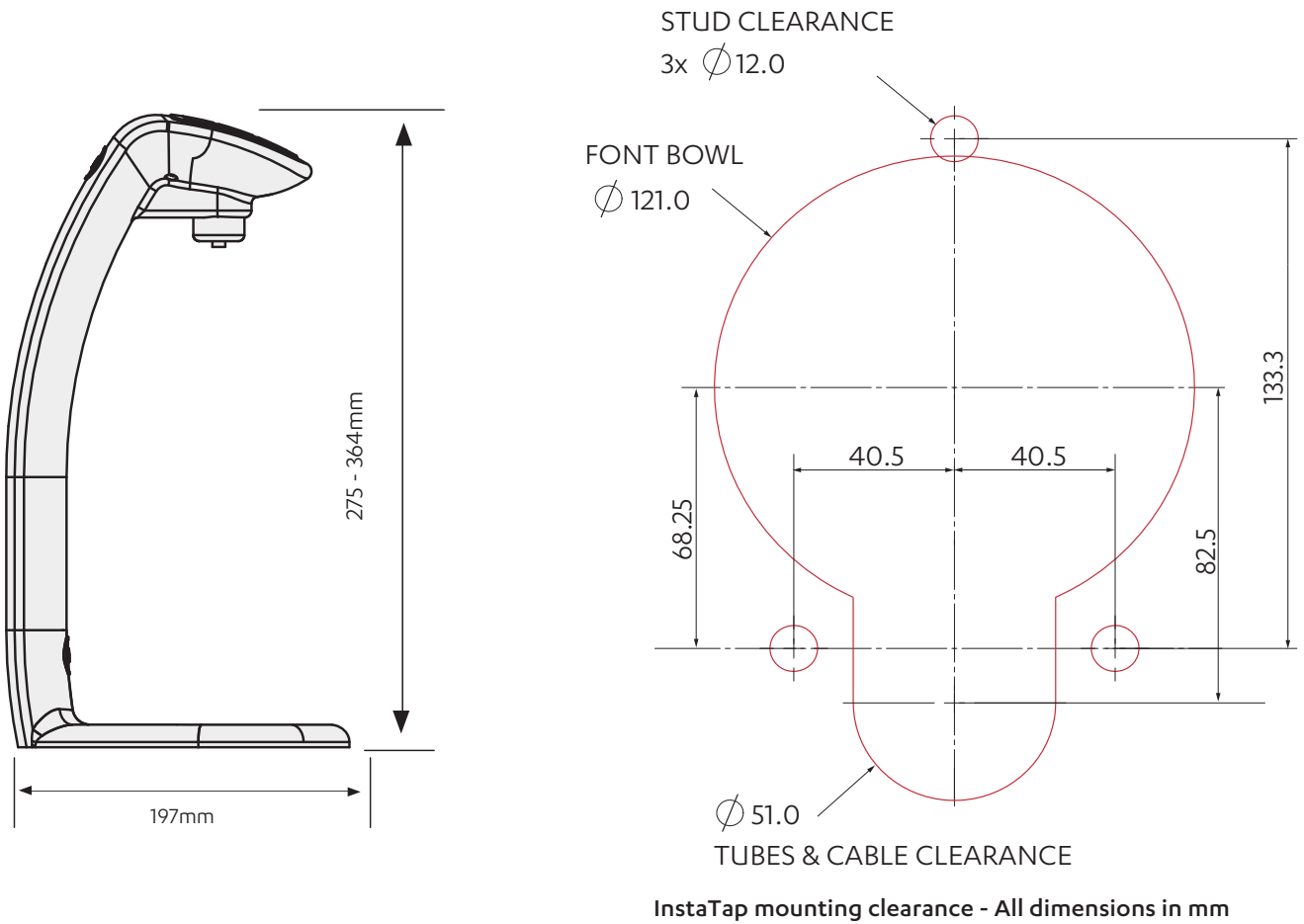

Under-counter unit installation

Clearance space required
for under counter unit

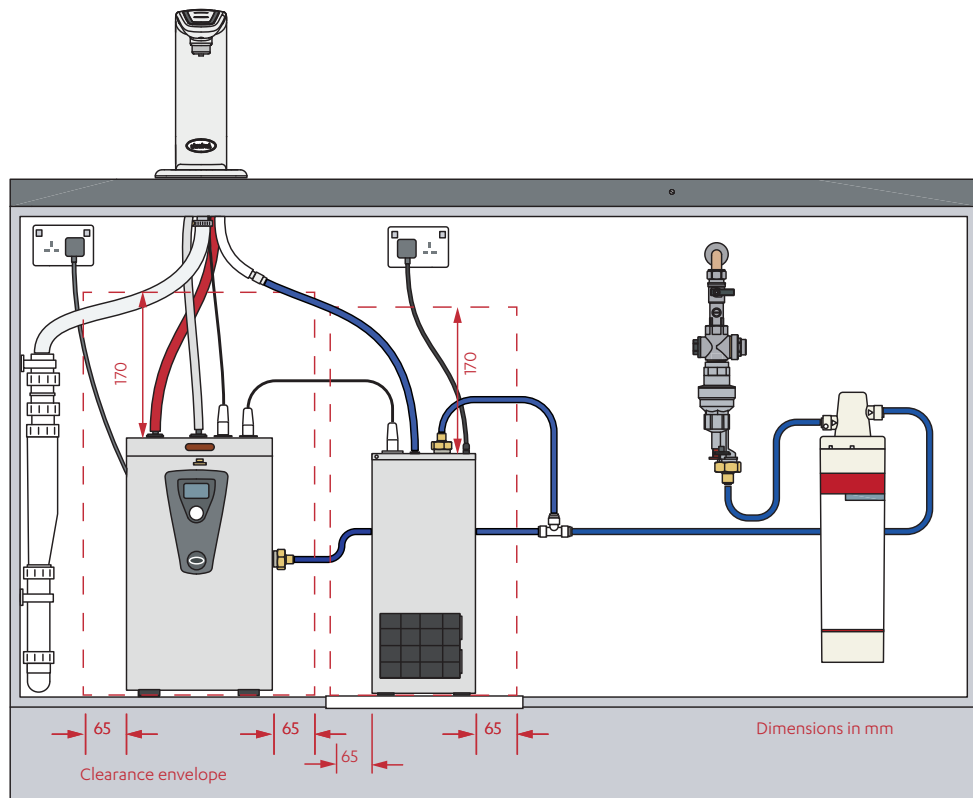

BC Comm 10 litre